



OPERATOR'S MANUAL



JOHN DEERE* 40/90 SERIES CORN HEADS

TABLE OF CONTENTS

Introduction	2
Warranty	2
Safety Section	2
Before Operation	3
Components List	4
Step 1 - Removing Old Stalk Rolls	5
Step 2 - Check Pinion Shaft Timing	6
Step 3 - Installing Calmer BT Chopper® Stalk Rolls and Grass Knives	7
Step 4 - Installing/Adjusting Calmer Stripper Plates	9
Step 5 - Installing Calmer 6-Tooth Drive and 9-Tooth Idler Sprockets and Gathering Chains	10
Installing Calmer's Anti-Hairball Insert	13
Helpful Corn Head Settings and Adjustments	14
Installing Calmer's Down Corn Gathering Chain Paddles	18

INTRODUCTION

Thank you for purchasing Calmer's BT Chopper® Upgrade Kit for your corn head. We hope you will get many years of productive use from it. The purpose of this upgrade kit is to improve your corn head's performance and accelerate corn residue decomposition. All product users must read and understand this manual prior to equipment operation. This manual is considered part of your machine and should remain with the machine at all times. Do not allow anyone to operate or maintain this equipment who has not fully read and comprehended this manual. Failure to follow the recommended procedures may result in personal injury or death or equipment damage.

Information in this manual is designed to help owners and operators to obtain the best results and safe operation from their investment. The life of these products depends largely on the care it is given and we suggest that the manual should be read and understood and referred to frequently. If for any reasons you do not understand the instructions and safety requirements, please contact us at any time. The intent of this manual is to provide guidelines to cover general use and to assist in avoiding accidents and injuries.

There may be times when circumstances occur that are not covered in the manual. At those times it is best to use common sense and contact our factory.

The requirements of safety cannot be emphasized enough in this publication. We urge you to make safety your top priority when using and maintaining this equipment.

WARRANTY

Calmer has been in business since 2004 and has an excellent reputation for quality and workmanship. Please contact us (the manufacturer) if you feel a component has not lasted to your expectation. These concerns will be handled on a case-by-case basis. Please contact our factory directly at (309) 629-9000 for replacement parts.



SAFETY

Read and understand this manual and all safety signs before maintaining and operating. Review the safety instructions and precautions annually.

TAKE NOTE!  THIS SAFETY ALERT SYMBOL FOUND THROUGHOUT THIS MANUAL IS USED TO CALL YOUR ATTENTION TO INSTRUCTIONS INVOLVING YOUR PERSONAL SAFETY AND THE SAFETY OF OTHERS. FAILURE TO FOLLOW THESE INSTRUCTIONS CAN RESULT IN INJURY OR DEATH.



THIS SYMBOL MEANS: ATTENTION! BECOME ALERT! YOUR SAFETY IS INVOLVED!

Note the use of the signal words DANGER, WARNING and CAUTION with the safety messages. The appropriate signal word for each has been selected using the following guidelines:



DANGER: Indicates an imminently hazardous situation that, if not avoided, will result in death or serious injury. This signal word is to be limited to the most extreme situations typically for machine components which, for functional purposes, cannot be guarded.



WARNING: Indicates a potentially hazardous situation that, if not avoided, could result in death or serious injury, and includes hazards that are exposed when guards are removed.



CAUTION: Indicates a potentially hazardous situation that, if not avoided, may result in minor or moderate injury.

NOTICE is used to address safety practices not related to personal safety.

This equipment is dangerous to children and persons unfamiliar with its operation. The operator should be a responsible adult familiar with farm machinery and trained in this equipment's operations. **Do not allow persons to operate or assemble this unit until they have read this manual and have developed a thorough understanding of the safety precautions of how it works.**



SAFETY SIGNS

Sharp Objects signs are placed on the exterior of all stalk roll boxes. Reference the danger sign on the left, and understand the cutting dangers with the enclosed product.



BEFORE OPERATION

- Carefully study and understand this manual.
- Do not wear loose-fitting clothing which may catch on moving parts.
- Always wear protective clothing and substantial shoes.
- Always wear provided cut-resistant gloves when installing stalk rolls.

THE CALMER UPGRADE KIT INCLUDES THE FOLLOWING PARTS PER ROW:

Your reference for left and right stalk rolls is from your perspective while sitting in the combine cab looking at the corn head.

Hydraulic Kit

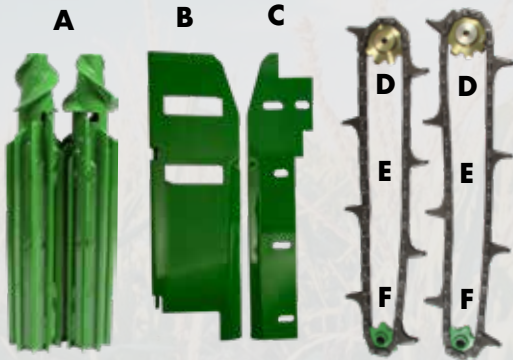

- A (2) BT Chopper® Stalk Rolls
- B (1) Left Hydraulic Stripper Plate
- C (1) Right Manual Stripper Plate
- D (2) 9-Tooth Idler Sprockets
- E (2) 48-Pitch Chrome-Pin Gathering Chains
- F (2) 6-Tooth Drive Sprockets

Manual Kit

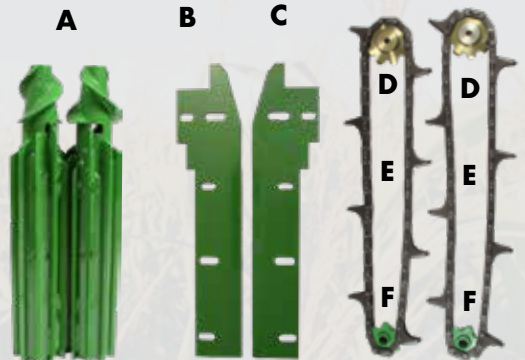

- A (2) BT Chopper® Stalk Rolls
- B (1) Left Manual Stripper Plate
- C (1) Right Manual Stripper Plate
- D (2) 9-Tooth Idler Sprockets
- E (2) 48-Pitch Chrome-Pin Gathering Chains
- F (2) 6-Tooth Drive Sprockets



(2) GRASS KNIVES



(1) ANTI-HAIRBALL INSERT



(2) CUT-RESISTANT GLOVES



(2) LOWER IDLER
SPRING WASHER



(4) STAINLESS STEEL
WASHERS



(1) 3/8" HEX BIT SOCKET



(4) 7/16" - 14 x 2"
SOCKET HEAD CAP SCREWS



(4) CONTINUOUS
ROLL PINS

STEP 1

Removing Old Stalk Rolls

! DANGER: Ensure the corn head is secured properly, combine lift cylinder stops are in place, equipment is turned off, and the parking brake is engaged.

1. Attach the corn head to your combine in accordance with the instructions in the manufacturer's owner's manual. **It is critical to lock the lift cylinder in the raised position before making any further adjustments.**
2. Remove the corn head dividers and hoods.
3. Lubricate the John Deere 8-tooth gathering chain drive sprocket shafts and gathering chain tightener threads with a penetrating type lubricant.
4. Release gathering chain tension. **Turn Nut A** until it is against the leg of the idler bracket support and completely compress spring. (See image A.)
5. Remove gathering chain and idler sprocket.
6. Remove the snap ring from the 8-tooth gathering chain drive sprocket shaft.
7. Remove the factory gathering chain drive sprocket. If the sprocket is rusted to the shaft, apply heat to the upper portion of the hub.
8. Remove idler blocks.
9. Remove chain guides.
10. Remove stripper plates.
11. Remove grass knives.
12. Remove stalk rolls.

Tapered & Straight-fluted Stalk Rolls – Consult your JD dealer for use of special hydraulic puller.

Pixall Stalk Rolls – Pixalls have a threaded doughnut inside of the nose cone. By using a fine thread bolt (1"x9") this will create its own self-pulling system when threaded into the nose cone.

JD Knife Roll Shells – Unbolt from stub shaft and remove stub shaft.

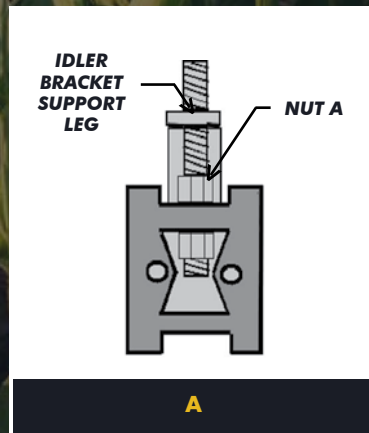



13. Clean rust from pinion shafts and check for leaks. Replace seals if necessary.
14. Inspect gathering chain drive shaft and bushing for wear.
15. Check seals on gathering and pinion shafts for leakage. Replace if necessary.

Check Pinion Shaft Timing

STEP 2

Before beginning assembly steps, check the timing by making sure the pinion shaft holes are exactly 90 degrees from each other. (Place 1/2" bolts in each roll pin hole to see more clearly.)

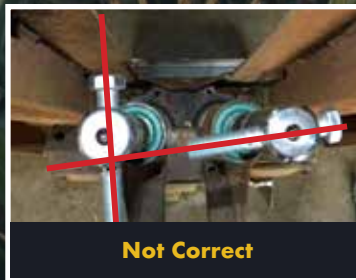
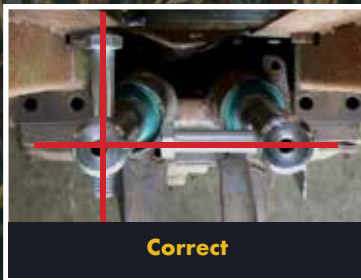

If the timing is not correct: loosen housing bolts and lift barrel 1/2". Rotate one shaft 180 degrees for proper timing.

To Correct The Problem:

- Leave the gear box on the corn head.
- Remove the stalk rolls.
- Clean around the stalk roll housing.
- Remove (8) 3/8" stalk roll housing bolts and (2) 5/8" frame mounting bolts. (See graphic right)
- Raise the stalk roll housing high enough to rotate 1 of the pinion shafts 180 degrees then set back down.
- Tighten stalk roll housing bolts.
- Install 1/2" bolts – ensure roll pins are placed at 90 degrees.

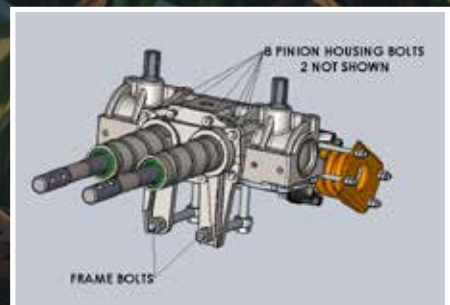

STEP 3

Installing Calmer BT Chopper® Stalk Rolls & Grass Knives



Rolls are marked on the left (L) and right (R) spirals and must be installed as a set, from the same box, as packaged from Calmer.

Important: Stalk rolls are to be installed from your perspective while sitting in the combine cab, looking at the corn head.

- ! CAUTION:** BT Choppers® are extremely sharp! Make sure that you are wearing the gloves provided with your order and that you handle the stalk rolls with extreme care.
 - ! NOTICE:** Corn head angle must be adjusted to 23-25 degrees in standing corn and 20 degrees in down/lodged corn for maximum performance and to avoid excessive wear on components! Failure to do so will void warranty!
 - ! NOTICE:** Older 40/90 series corn heads had welded cluster gears, which have been known to fail after many years of use. JD sells a new cluster gear design, which was a pip update to fix this issue. Because this system may accelerate the failure of the older cluster gears, it is recommended to keep an extra cluster gear on-hand for potential maintenance repairs.
1. Apply any anti-seize substance on the front 3" of the shaft. This will make the removal of stalk rolls easier in the future when checking seals on the gearboxes.
 2. Slide Calmer BT Choppers® onto gearbox pinion shaft.
 3. Install the provided continuous roll pins into the stalk rolls, which will allow for equal recession on each side and secure the stalk rolls to the gearbox shafts.
 4. Insert socket head bolts into each countersunk hole. Hand start the 7/16" bolts on the countersunk side of the stalk roll. Start both bolts front and back at the same time.

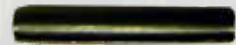

CONTINUOUS ROLL PINS

Only torque to 85 lb-ft. We recommend using medium-strength threadlocker on the bolts.

- After installation, if your stalk roll flutes contact each other and do not intermesh correctly, then it is likely that the gearbox has been re-worked. **The roll pin holes in the pinion shafts must be exactly 90 degrees from each other.** For reference or to correct the problem, see page 6.
- Ensure clearance between BT Chopper® Stalk Rolls and Calmer Stripper Plates. Shim the row unit if there is not sufficient clearance.

Calmer Grass Knives

! NOTICE: To prevent possible damage to stalk rolls or grass knives, there must be a minimum 1/4" gap between the stalk roll spirals and grass knives. Also, ensure a minimum 2 1/8" gap between the front of the grass knives. (See figures 2 & 3 below)

- If using JD grass knives, only JD straight grass knives can be utilized and may need further modification. Maintain a minimum 1/4" gap between the grass knives and the stalk roll. This is measured from the top of the longest blade to the edge of the grass knife. Repeat the above steps to install the remaining stalk rolls.

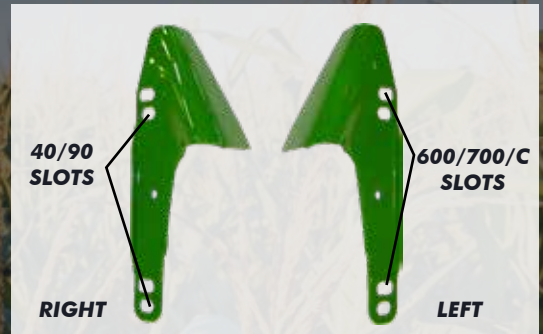

Reference the graphic above for bolt hole locations to be utilized during installation of grass knives.

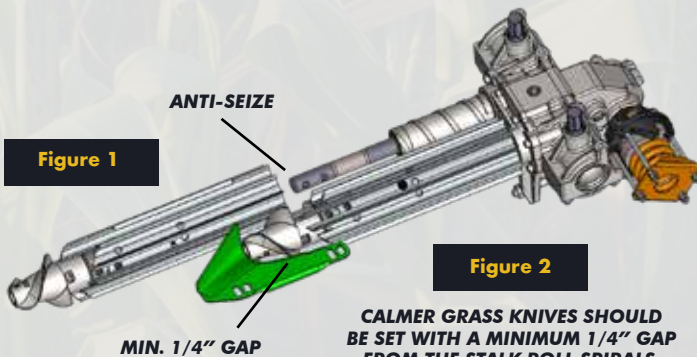

Figure 2

CALMER GRASS KNIVES SHOULD BE SET WITH A MINIMUM 1/4" GAP FROM THE STALK ROLL SPIRALS.

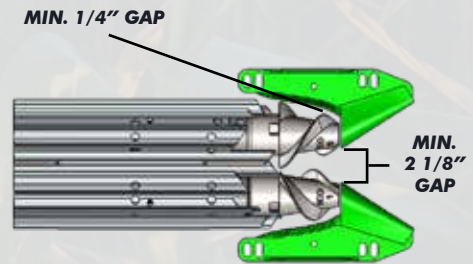

Figure 3

(BOTTOM VIEW)



Recommended Stripper Plate Adjustments:

Begin with normal settings of 1 1/8" gap at the front and 1 3/16" gap at the rear, then adjust accordingly to ensure plates are 1/16" wider than the diameter of the 3rd cornstalk node from the brace root.

Hydraulic and Manual Plates:

Below are instructions for setting hydraulic and manual Calmer Stripper Plates:

With the left hydraulic or manual plate installed and in the open position, move it towards the center of the row unit until the edge of the plate is half of the desired width from the centerline of the row unit (tighten down manual plate here). Next, insert a block that matches the desired plate gap between the two plates (1 1/8" gap at the front and 1 3/16" gap at the rear). Then slide the right manual plate in tight to the block and tighten down to set it in place.

For Hydraulic Plates Only: Once the stripper plates are at the desired gap, mark the gauge on the frame or write down the value given in the cab for future reference. This is the ideal spot for the hydraulic stripper plates to match your initial settings.

Installing Calmer 6-Tooth Drive and 9-Tooth Idler Sprockets and Gathering Chains

STEP 5

1. **This Step is for 40 Series Corn Heads Only! 90 Series Customers Should Start at Step # 2.** On the first and last rows only, carefully remove the angle iron (see photo on right) in the gathering chain drive sprocket area. Move bracket toward the inside so that the gathering bracket doesn't make contact with the gathering chain, and re-weld in place for hood support. Completely remove the angle iron on all other rows.



2. Inspect chain guides & idler blocks for wear.

Important: You must use stainless steel washers with Calmer's 9-Tooth Idler. Some modification may be required when installing. (See below image.)

3. Disassemble the old idler sprocket. Discard the greaseable bushing & O-ring as it is not used with the new sprocket design.

Gathering Chain Tighteners

Gathering chain tighteners occasionally lock up. This is caused when the spring vibrates and augers itself into the hole between the bolt and the flat strap. This can be fixed by removing the idler bolt and adding a second washer (enclosed) at the bottom of the pipe spacer, which is identical to the washer at the top of the pipe spacer (see photo below). Apply anti-seize or lubricant to the bolt threads for future adjustments.



4. Inspect to see if plow bolt shoulder extends above the idler strap.



- If the plow bolt shoulder extends above the idler strap then you must smooth out the shoulder with a grinder until flush with the idler strap.
- If the plow bolt shoulder is flush or does not extend above the idler strap, no further modification is required.

5. Reassemble the 9-tooth idler sprocket by inserting the plow bolt through the idler strap.



6. Place 1 stainless steel washer (provided) on the plow bolt.



8. Place 1 stainless steel washer (provided) on top of the 9-tooth idler sprocket.

7. Install the 9-tooth idler sprocket with the **teeth beveled on 3 sides facing up**.

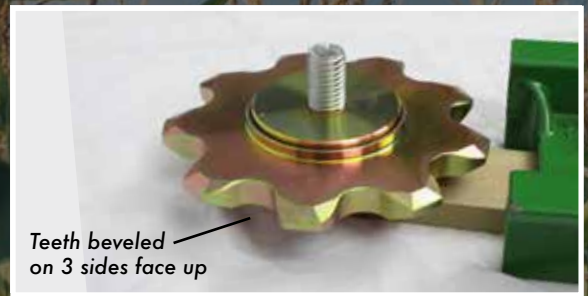

9. Reinstall 5/8" lock washer and nut (some heads have a regular 5/8" washer and lock nut) and torque to 100 lb-ft. (Slight resistance when turning sprocket by hand is normal.)

10. Oil the gathering chain drive shaft.

11. Place the gathering chain around the idler sprocket.

12. Insert the 6-tooth sprocket in the chain at the drive end. Some farmers get concerned that the tighter wrap on the 6-tooth sprocket might cause excessive wear on the top end of the chain guard. While there may be some initial wear, the rollers on the gathering chain will eventually run on the chain guard and keep it from wearing any further. Marion used to run 5-tooth sprockets at the top and never had any trouble with excessive wear. (See photo on right.)

13. Time gathering chain lugs.

For Standing Corn: Install the gathering chain lugs so the lugs are staggered.

For Down Corn: Install the gathering chain lugs so they are directly opposed from each other. Adding oversized paddles will also help in harvesting down corn. **These oversized down corn gathering chain paddles are available for purchase from Calmer Corn Heads.**

14. Replace the top snap ring on the shaft. Ensure the snap ring is properly seated on the hex shaft.

15. **This step is for 40 Series corn heads only!** Adjust the top of the gathering chain guides as far away from the center of the row unit as possible.

16. Tighten the gathering chain tightener until there is a 3/16" clearance between the pipe spacer and washer. Apply anti-seize or lubricant to threads for future adjustments.

17. Test for proper installation of components. To ensure proper installation of components, using the feeder house reverser, operate corn head for 10 seconds. Next, operate corn head normally at idle then gradually increase to full speed.



INSTALLING CALMER'S ANTI-HAIRBALL INSERT

"Hairball" is a term we use to describe the mass of cornstalks that gathers and hairpins at the top of the stripping tunnel in damp conditions.



PROBLEM

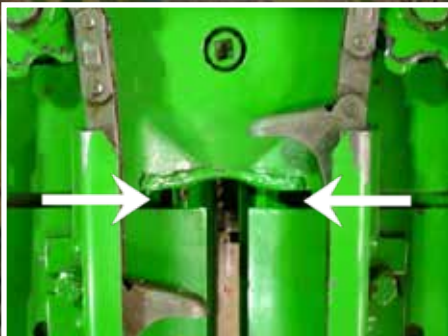

Gaps at the end of the stripping tunnel



In wet conditions, debris (hairball) gets caught

OUR SOLUTION

! DANGER: Disconnect Battery!

1) Weld enclosed anti-hairball insert to top plate of the gearbox and fill in any gap.



2) Manual Plates: Tac weld both manual plates to anti-hairball insert.



2) Hydraulic Plates: Tac weld ONLY manual plate to anti-hairball insert. Hydraulic plate must be able to move.



3) Grind insert flush with stripper plate.

HELPFUL CORN HEAD SETTINGS & ADJUSTMENTS

Marion's Recommended Sieve Adjustments for Corn: I personally disagree with the suggested sieve settings in many owner's manuals. Below is what I've found to be most successful throughout my years of farming.

Bottom Shoe Sieve: Run wide open. Try this one round to gauge effectiveness.

Top Chaffer Sieve: Close until sample in the grain tank is clean.

Reason: When harvesting corn, the bottom sieve is not needed. There is no part of the kernel that needs to be re-threshed! Therefore, the bottom sieve should be wide open. This allows the kernels to fall directly into the clean grain auger.

Results of my Recommended Sieve Settings:

1. More capacity
2. More air to top sieve
3. Less separator loss
4. Less cracks in dry corn
5. Less grinding in wet corn
6. Less plugging of return elevator in wet corn



Corn Head Angle: A properly adjusted corn head angle is critical to its performance. For optimum performance and to retain Calmer's warranty on parts, the corn head angle **MUST** be set between 23-25 degrees in standing corn and 20 degrees in down/lodged corn.

Setting Your Corn Head Angle: The angle of the corn head should be between 23-25 degrees for optimum performance in standing corn. The angle should be set to 20 degrees in down/lodged corn. Flattening the angle to 20 degrees in down corn makes gravity less of an enemy. To set the corn head angle, put the combine on a level surface, then lower the corn head until the row unit frame is 2 inches off the ground. Place a magnetic protractor (included with all stalk roll and residue management kit purchases) on the stripper plate and read the angle (See picture above). If the angle is too steep, pull the top of the corn head toward the combine or push out the bottom with a wedge kit, or a combination of both.

Setting Gathering Chain Speed to Match Ground Speed:

Begin calibration with initial gathering chain speed of 55 RPMs. If butt shelling is a problem, slow down the corn head speed until it starts to bulldoze cornstalks, then speed back up until bulldozing stops. Note: If RPMs are too fast, trash intake and butt shelling increase. If RPMs are too slow, you may experience poor stalk chop, row unit bulldozing and ear loss.

Cross Auger Flighting: Cross auger should be vertically adjusted to have 1 3/4-inch clearance between the auger flighting and tray at the tightest point. This significantly reduces ear slicing which is a cause of cracked kernels in the grain tank. When you turn on the end rows, there should be a layer of ears between flighting and the tray.

We DO NOT recommend using any rubber paddles on the cross auger. We recommend that you fill-in any holes on the tray and grind them flush. This will help stop the loss of kernels and kernel damage.

Use Reverse Flighting on 30-Foot Split Cross Augers

Some older John Deere corn heads used rubber flaps and no reverse flighting. The performance of the older auger is poor. Other John Deere split cross augers had no reverse flighting near the bearing hanger. The short section of reverse flighting can be purchased from John Deere (right hand part #H206301, left hand part #H206302) and welded on. (See photo to the right.)

Reducing Ear Toss:

Cross auger should be horizontally adjusted rearward, as close to the feeder house chain and rear stripper as possible. This will improve the transfer of material from the cross auger to the feeder house chain, thus reducing ear toss.

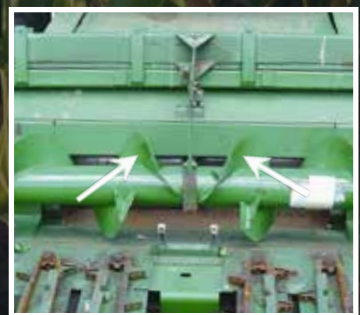

Add half and/or full links to lengthen the feeder chain. This will reduce the dead air space between the feeder chain and cross auger flighting.

Stay on the fast setting (large sprocket) for the feeder house chain speed when harvesting corn to decrease ear toss. This can be adjusted on the lower right-hand side of the feeder house.

Note: It is possible for feeder house ear tossing to increase as a result of minimal trash intake.

For 40 Series and Older 90 Series Corn Heads Only: Using a 64-tooth sprocket (JD Part # AH145940) on the cross auger instead of the factory 54-tooth will slow the auger down and help reduce ear toss. This 64-tooth sprocket uses a #50 roller chain. The new 90 series corn head cross augers come from the factory already slowed down with a 52-tooth sprocket that uses a #60 roller chain.

Oil Bath Settings

The corn head should have the oil bath in overdrive, the large sprocket on the back (driver), and the small sprocket on the front (driven).

40/90 Corn Head Gear Ratios

- 693: 30 Driver; 25 Driven
- 893: 30 Driver; 25 Driven
- 1293: 22 Driver; 18 Driven
- 1290: 22 Driver; 18 Driven

JD Corn Head on Case Combine or non-variable speed Feeder House Combine

- JD 693: 34 Driver; 22 Driven
- JD 893: 34 Driver; 22 Driven

Feeder House Settings for JD Combines

Standing Corn: 600-610 RPM on variable speed. As previously mentioned, we suggest staying on fast setting (large sprocket) for the feeder chain speed when harvesting. Further instructions:

- Must have heavy duty reverser (8 rows or above have a finned aluminum cooler (recommended by John Deere).
- Only use fully synthetic oil in the reverser.
- There are 2 grease fittings on the reverser. These need to be placed at the 12 o'clock and 2 o'clock positions. Put 12 pumps of grease in the fitting located at 12 o'clock and 2 pumps of grease in the fitting located at 2 o'clock. **Do Not Over Grease!**
- Once you start-up the machine, at idle, run the variable speed up and down twice to lubricate properly prior to harvest.

Down Corn: 500-550 RPM on variable speed.

Adjusting Slip Clutches According to JD Owner's Manual

Slip clutches protect the corn head drives. Each row unit drive and auger drive have a slip clutch, which are properly adjusted at the factory. The only time slip clutches require adjusting is after they are disassembled for service. The length of the row unit slip clutch spring (figure A), when properly adjusted, must be 68 mm or 2 11/16-inches. The auger drive slip clutch is non-adjustable.

Important: Do not tighten nuts to the point where the clutch will not slip. Compress the four jam nuts to compress the spring washer. Torque to 75 N-m (55 lb-ft). Grease thrust washer but do not grease clutch facings.

Gear Box Lubricant

Check the gear case lubricant level at inspection plugs (figure B). Lubricant must be approximately 38 mm (1 1/2 inch) from the top of the inspection hole. Fill to approximate level with John Deere Corn Head Grease using grease fitting on the bottom of the gear case.

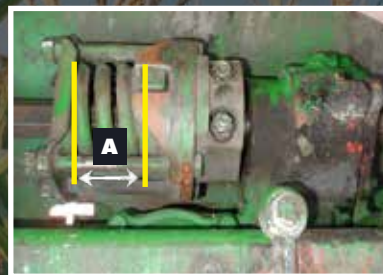

INSTALLING CALMER'S DOWN CORN GATHERING CHAIN PADDLES

Follow the instructions for assembly of plastic gathering chain paddles and attach to every other lug on each gathering chain. (One orange paddle is used on the row left of the feeder house in front of the buddy seat for calibrating corn head speeds.)

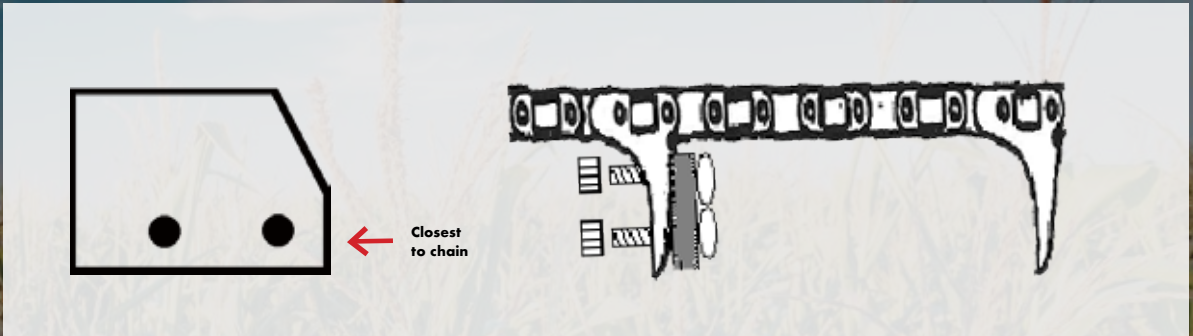

1. Install and hammer the two provided carriage bolts into each paddle, ensuring the bolt shoulders are seated in the paddles. Repeat for remaining paddles and bolts, while being careful to not damage threads.
2. Install paddles on every other lug of the gathering chain, ensuring the bevel is closest to the chain. (See graphic above for reference) Use a standard 7/16" socket to install and tighten lock nuts.
3. Repeat steps for remaining rows.





"Thank you for purchasing Calmer Products to improve your corn head and residue management capabilities on your farm."

Marion Calmer

CEO – Calmer

President – Calmer Ag Research Center

Owner/Operator – Calmer Farms



P.O. Box 9 | Alpha, IL 61413 | (309) 629-9000 | fax (309) 629-9001

www.CalmerCornHeads.com

*Trademarks are not owned by, affiliated with, or under license to Calmer and used solely for the utility of Calmer products mentioned herein.

The replacement parts comprising and the methods associated with Calmer's Residue Management Program are covered by the following patents issued by the United States Patent and Trademark Office: 7,886,510, 8,171,708, 8,220,237, 8,464,505, 8,857,139, 8,863,487, 9,554,511, 9,560,804, 9,668,414, 10,039,232, 10,045,483

Calmer Limited Warranty

Calmer warrants our parts 100%. This warranty is good throughout the first season after purchase of the part.

What this means is that if the part breaks within the first season of use, we will replace the part with a new one without charge to you. Calmer pays for the shipping both ways as well. In the alternative, if you wish, we will refund to you all of the money you paid to Calmer for the part. If the Calmer part does not work in a manner that you expected, we promise that we will work with you to adjust settings and to see if we can obtain satisfactory performance. In the end, if the Calmer part does not work on your farm to your complete satisfaction, we will refund your purchase price.

Disclaimers: Calmer is not responsible for and does not warrant as to consequential damages or any other types of damages that may be claimed as a result of part breakage or unsatisfactory performance. In other words, except as stated herein all other warranties or liabilities, expressed or implied, oral or statutory, including any warranty of merchantability or fitness for a particular purpose are expressly denied.

**TO OBTAIN WARRANTY SERVICE:
CALL 309-629-9000**

**FOR EMERGENCY REPAIRS:
CALL 309-368-1182**

September 2022